

# 25,000 LB. TOP COMPRESSION PANEL BOARD STRAPPING SYSTEM

AUTOMATED STRAPPING SYSTEMS

Incredible strength, long life and continuous operation. Efficiency and respect for your production needs. Only Itipack technology can give you these machines.

They spring from state-of-the-art production lines where the creation of every single part is governed perfectly by automation.

Everything is Itipack-made: the structural metalwork, the painting, the mechanical and electrical assemblies.

They are then subjected to the severest tests: residual tension testing by tensionmeter and tensile strength testing by dynamometer both on steel and plastic straps.



## TECHNICAL DATA:

### Model VKP

Hydraulic powered high compression strapping machine.

### Strapping Head

Itipack model VK-120-19 (VK-30) high-tension plastic strapping head (Option steel: Standard triple notch sealless head, AAR approved. Fromm M100 or Itipack VS-11)

### Compression

Up to 25,000 lbs top compression hydraulically powered, heavy duty rack and pinion equalized.

### Hydraulic Power Pack

Variable volume piston pump (100 gallon tank, 20 HP motor)

### Package Parameters

60" maximum width  
24" minimum width  
50" maximum height  
9" minimum height

### Strap Track

Telescopic vertical tracks enable strap feed at any height thru full range of travel. Hardened spring loaded gates.

### Strapping Dispenser

Itipack model PDAT-100 powered dispenser complete with accumulation tower (for standard coil sizes).

### Automation Control

Allen Bradley programmable logic controller with operator interface devices. (Other brands available upon request).

### Power Requirements

575/480 volt, 3 phase, 60 Hz

### Available Options

- Top, fibre corner protectors
- Bottom, fibre corner protectors
- Double magazine, top and bottom bunk applicators, (multiple magazine bunk applicators also available)
- Itipack model PDAT-160 jumbo strap dispenser (capacity 160 lb)
- Itipack model PDAT-350 super jumbo strap dispenser (capacity 350 lb)
- Heavy duty hydraulic side compression

*Machine componentry customization available.*

*Consult factory for pricing and availability.*

**Itipack Systems**

919 Zelco Drive Burlington Ontario Canada L7L 4Y2 t. 905 333 3695 f. 905 681 3172

[www.itipacksystems.com](http://www.itipacksystems.com)



# 25,000 LB. TOP COMPRESSION PANEL BOARD STRAPPING SYSTEM

Steel Strap	Plastic Strap
Strap Width: from 1/2" up to 3/4"	Strap Width: from 5/8" up to 3/4"
Strap Thickness: from .02" up to .025"	Strap Thickness: from .03" up to .05"
Strap Tension: adjustable up to 2000 lb.	Strap Tension: adjustable up to 1100 lb.
Sealing Method: triple notch sealless	Sealing Method: heat seal
Seal Efficiency: 85% of strap breaking strength	Seal Efficiency: 90% of strap breaking strength

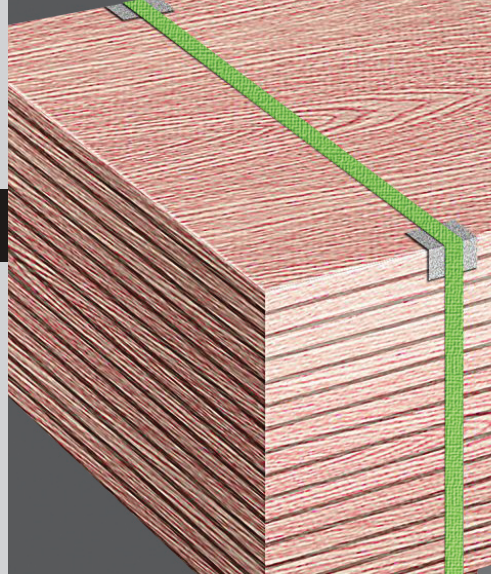

ITEM	VALUE
A BUNK FEEDER WIDTH	55"
B BUNK FEEDER LENGTH	115"
C BUNK FEEDER HEIGHT	110"
D STRAPPING MACHINE WIDTH	45"
E STRAPPING MACHINE LENGTH	130"
F STRAPPING MACHINE HEIGHT	129"
G OVERALL LENGTH	245"

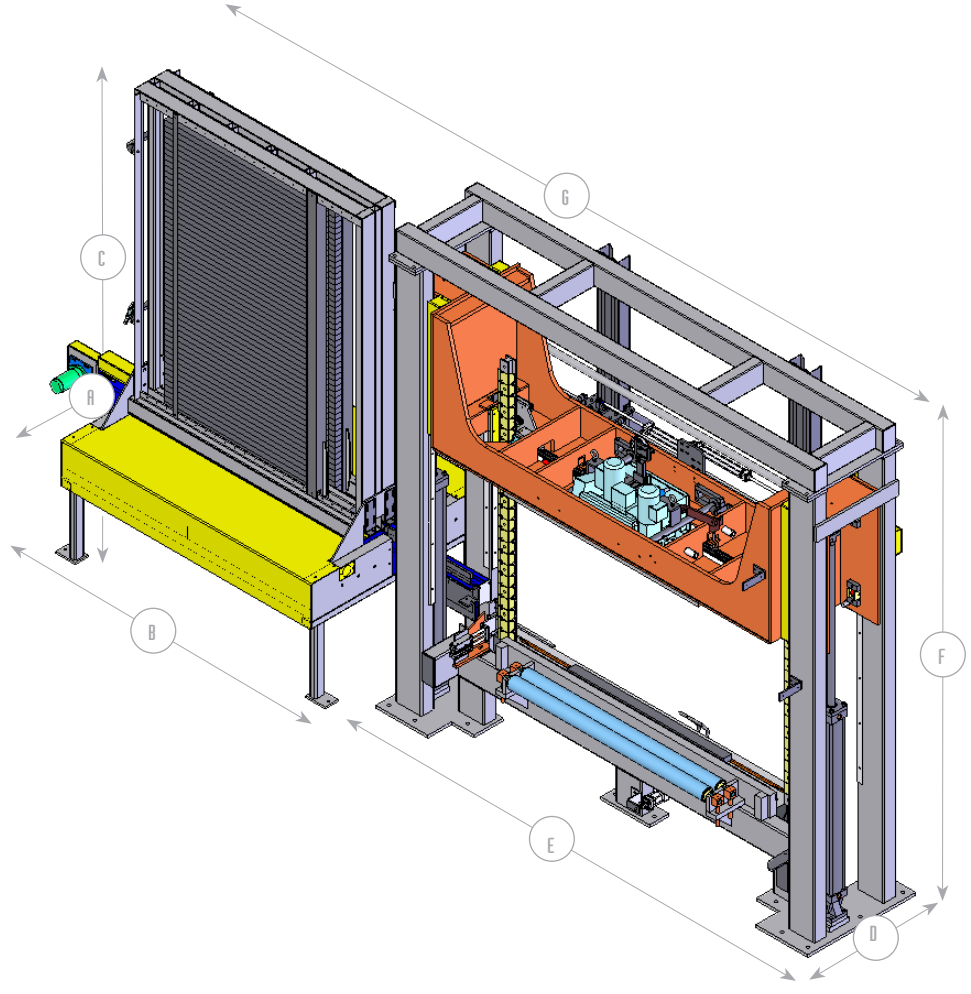

919 Zelco Drive Burlington Ontario Canada L7L 4Y2  
 phone 905 333 3695 facsimile 905 681 3172  
 email info@itipacksystems.com  
 web www.itipacksystems.com

